

# COQUERIA

## **CARACTERÍSTICAS DA COQUERIA**

**TIPO: KOPPERS UNDERJET**

**Nº DE BATERIAS: 02**

**Nº DE FORNOS POR BATERIA: 53**

**LARGURA MÉDIA DOS FORNOS: 457 mm**

**COMPRIMENTO: 15.424 mm.**

**ALTURA: 6.250 mm**

**VOLUME ÚTIL: 39.8 m**

**CARGA POR FORNO: 28,88 t.**

**PRODUÇÃO COQUE / DIA: 3.200 t**

# EFETIVOS

PRÓPRIO - 101

CONTRATADO - 79

## FLUXOGRAMA DO CARVÃO DA ORIGEM ATÉ USINA

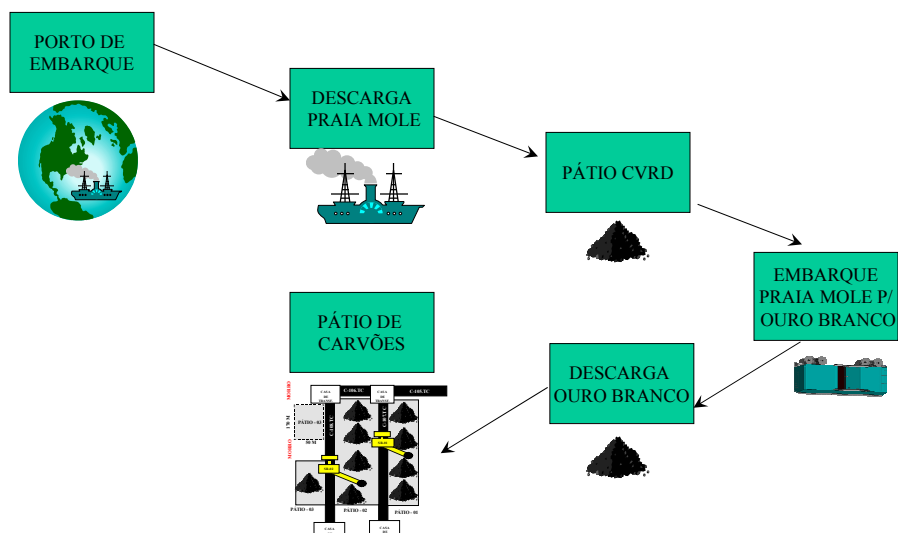

## RECUPERAÇÃO DE CARVÃO NO PÁTIO

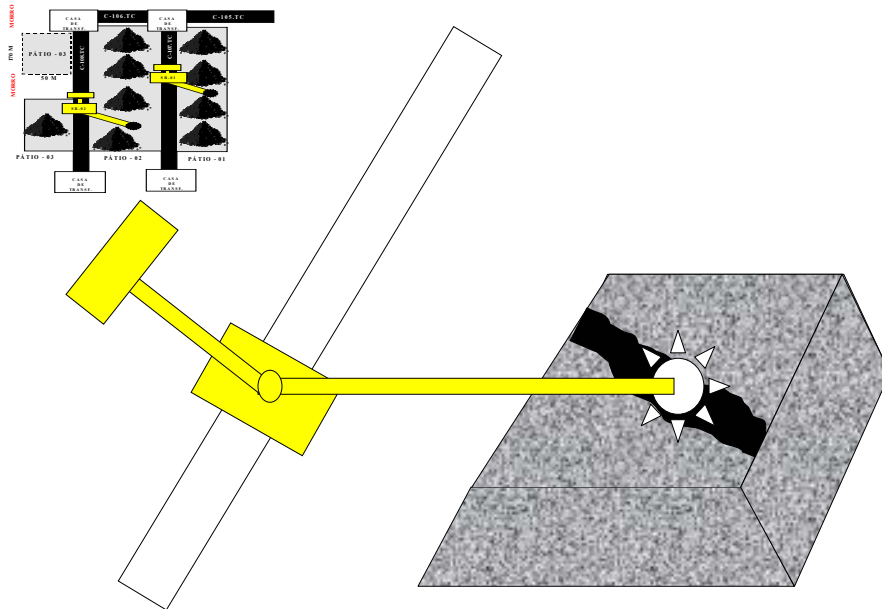

## BRITADOR DE CARVÕES

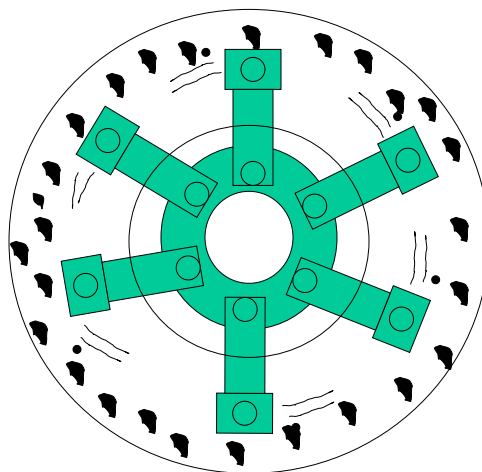

**SILOS DOSADORES DE CARVÕES**

VISTA DE TOPO

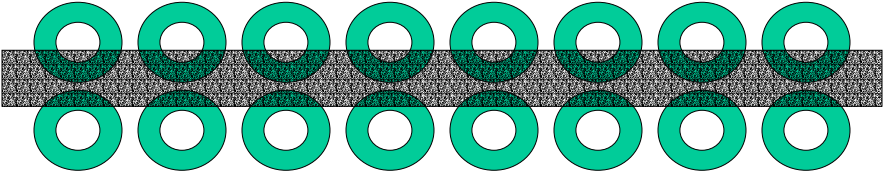

**Carro de Carregamento 1**

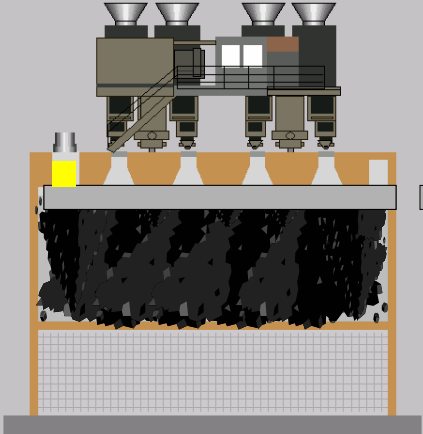



## Sistema de Aquecimento - Bateria 1

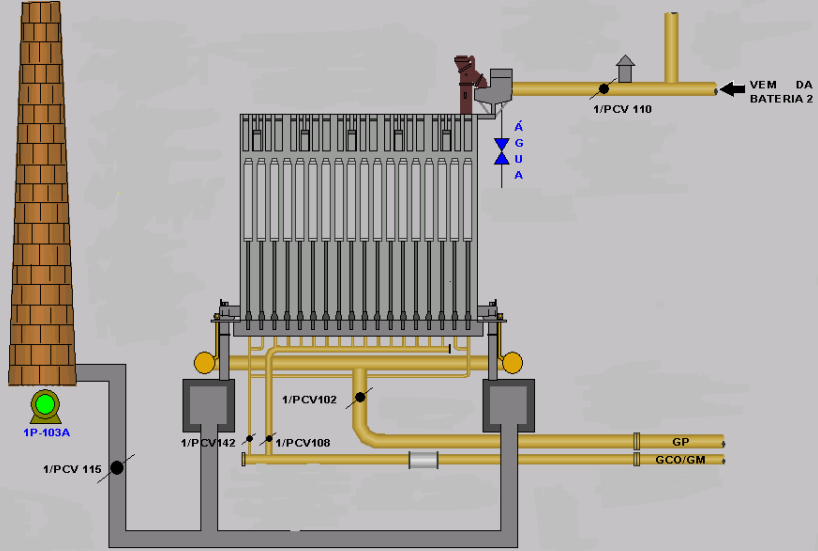

## Máquina Desenfomadora 1

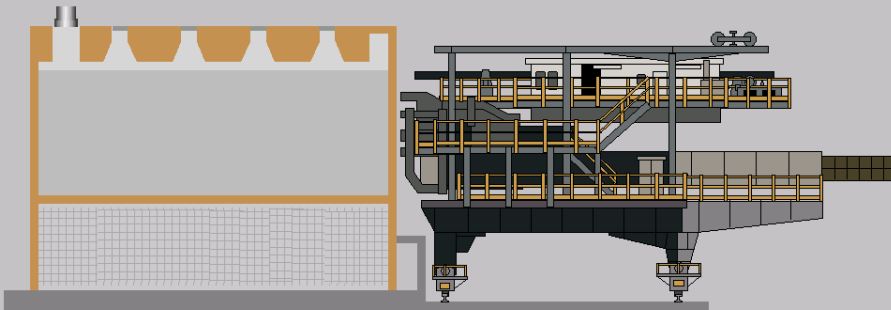



## Guia de Coque

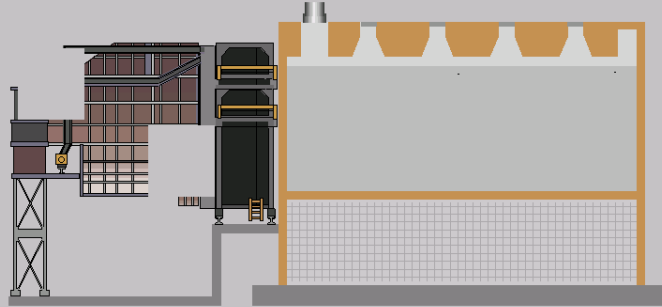

## Carro de Extinção 1

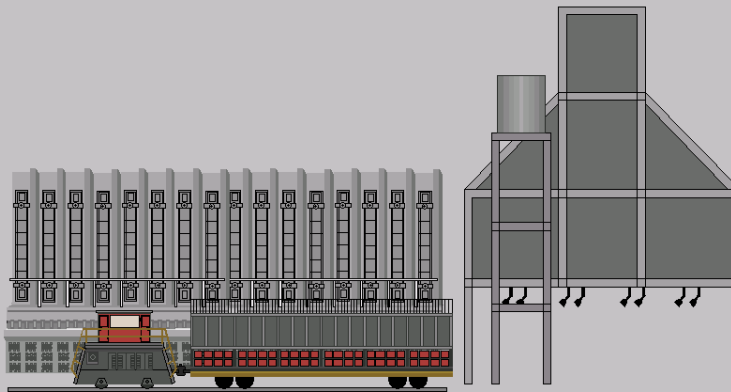

## SISTEMA DE TRANSPORTE DE COQUE

